



Product Presentation
Bun Divider Rounders
& Dough Dividers





Large capacity for both soft and stiff doughs

The Glimek Bun Divider Rounder and Dough Divider range includes both semi-automatic, 3/4 automatic and automatic bun divider rounders – all with easy and quick operation.

The aluminum moulding table reduces the weight of moving parts and gives a silent operation with a minimum of vibration and gentle dough treatment for a perfect end product.

Find out more on our website www.sveba-dahlen.com

Bun Divider Rounder and Dough Divider Range

Bun Divider Rounder

BDM

Semi-automatic Bun Divider Rounder



BD34

3/4-automatic Bun Divider Rounder



BDA

Automatic Bun Divider Rounder



BDE

Electronic Automatic Bun Divider Rounder



Hydraulic Dough Divider

HDD/HDS

Hydraulic Dough Divider



HDD/HDS

Electronic Hydraulic Dough Divider





Bun Divider Rounder

BDM – Semi-Automatic Bun Divider Rounder

Treats the dough gently and makes perfectly rounded dough rolls. Ergonomic and easy to use.

Features

Dividing disc with non-stick coating. Aluminum moulding table.

The disc can be tilted forward for easy cleaning. Three easy to clean moulding plates included.

Options

- Extra moulding plates



Technical

MODEL	PIECES	WEIGHT RANGE	MAX DOUGH WEIGHT*
BDM-2/30	30	25-85 g	2,55 kg
BDM-3/30	30	30-100 g	3 kg
BDM-3/36	36	25-85 g	3 kg
BDM-3/52	52	18-50 g	3 kg
BDM-4/14	14	130-250 g	4 kg
BDM-4/30	30	40-130 g	4 kg
BDM-4/36	36	30-110 g	4 kg

El. load 0.55 kW

**subject to dough consistency*

Measurements

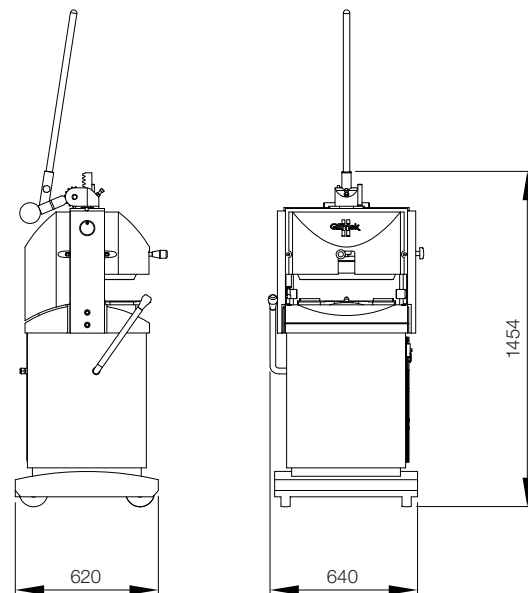

Bun Divider Rounder

BD34 – 3/4-Automatic Bun Divider Rounder

A 3/4 automatic dough divider rounder that divides and rounds dough pieces into equal sizes. The machine works entirely by hydraulics, making it more dough friendly and easy to handle.

Features

- Precise regulation of rounding chambers. Maximum flexibility.
- Easy cleaning, with three easy to clean moulding plates included.

Options

- Extra Dividing Disc
- Extra moulding plates



Technical

MODEL	PIECES	WEIGHT RANGE	MAX DOUGH WEIGHT*
BD34-2/30	30	25-85 g	2,55 kg
BD34-3/30	30	30-100 g	3 kg
BD34-3/36	36	25-85 g	3 kg
BD34-3/52	52	18-50 g	3 kg
BD34-4/14	14	130-250 g	4 kg
BD34-4/30	30	40-130 g	4 kg
BD34-4/36	36	30-110 g	4 kg

El. load 1.3 kW

**subject to dough consistency*

Measurements

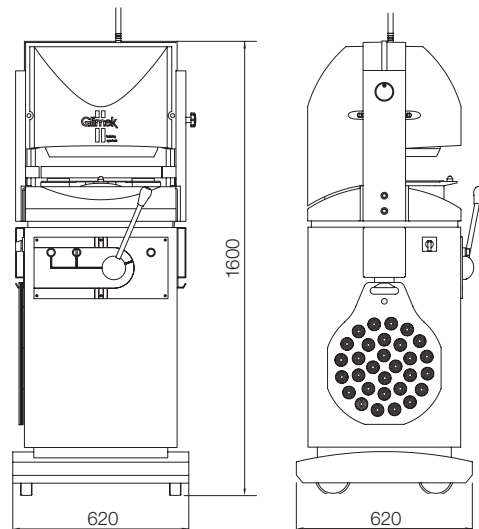

Bun Divider Rounder

BDA – Automatic Bun Divider Rounder

An automatic dough divider rounder that divides and rounds dough pieces into equal sizes. Weight adjustment through electronic control.

Features

Precise regulation of rounding chambers. Programmable with pressing and rounding times, divide-only, press-only and cleaning positions, memory for 10 different products.

Easy cleaning with three easy to clean moulding plates included.

Options

- Extra Dividing Disc
- Extra moulding plates



Technical

MODEL	PIECES	WEIGHT RANGE	MAX DOUGH WEIGHT*
BDA-2/30	30	25-85 g	2,55 kg
BDA-3/30	30	30-100 g	3 kg
BDA-3/36	36	25-85 g	3 kg
BDA-3/52	52	18-50 g	3 kg
BDA-4/14	14	130-250 g	4 kg
BDA-4/30	30	40-130 g	4 kg
BDA-4/36	36	30-110 g	4 kg

El. load 1.3 kW

**subject to dough consistency*

Measurements

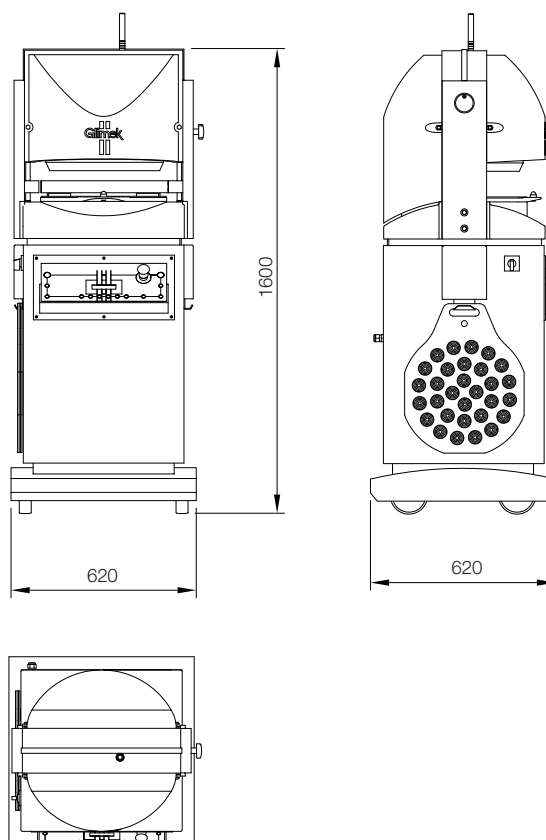

Bun Divider Rounder

BDE – Electronic Automatic Bun Divider Rounder

An electronic automatic dough divider rounder that divides and rounds dough pieces into equal sizes. Weight adjustment through electronic control.

Features

Precise regulation of rounding chambers. Programmable with pressing and rounding times, divide-only, press-only and cleaning positions, memory for 10 different products.

Easy cleaning, with three easy to clean moulding plates included. Adjustable rounding stroke and rounding speed

Options

- Extra Dividing Disc
- Extra moulding plates

Technical

MODEL	PIECES	WEIGHT RANGE	MAX DOUGH WEIGHT*
BDE-2/30	30	25-85 g	2,55 kg
BDE-3/30	30	30-100 g	3 kg
BDE-3/36	36	25-85 g	3 kg
BDE-3/52	52	18-50 g	3 kg
BDE-4/14	14	130-250 g	4 kg
BDE-4/30	30	40-130 g	4 kg
BDE-4/36	36	30-110 g	4 kg

El. load 1.3 kW

**subject to dough consistency*



Measurements

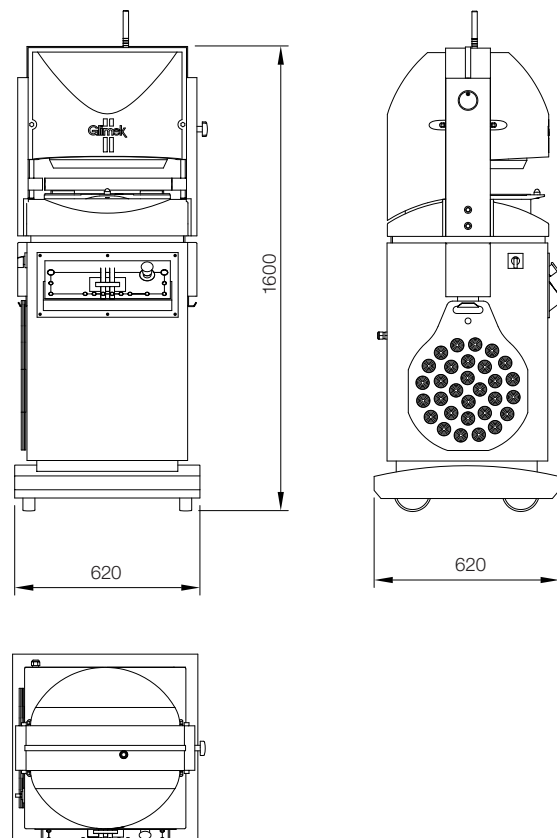

Hydraulic Dough Divider

HDD/HDS – Hydraulic Dough Divider

Semi-automatic hydraulic dough divider divides dough into equal round or square pieces. Hygienic due to interior chamber in stainless steel.

Features

Programmable electronic panel with digital readout. Automatic blade rasing for easy cleaning of the stainless steel knives. Adjustable pressing time for more flexibility.

Dough chamber capacity: 18 kg (round), 20 kg (square). Movable on 4 wheels, 2 lockable.



HDD

HDS

Technical

MODEL	PIECES	WEIGHT RANGE*	TYPE OF DOUGH DIVIDER
HDD-16	16	250-1100 g	Round
HDD-20	20	200-900 g	Round
HDD-24	24	180-750 g	Round
HDS-10	10	480-2000 g	Square
HDS-20	20	240-1000 g	Square

El. load 1.1 kW

**subject to dough consistency*

Measurements

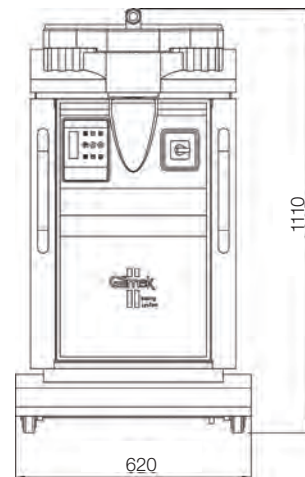

Hydraulic Dough Divider

HDD/HDS – Electronic Hydraulic Dough Divider

Electronic hydraulic dough divider divides dough into equal round or square pieces. Hygienic due to interior chamber in stainless steel.

Features

Electronic panel with digital readout. Automatic opening and closing of the lid. Automatic blade rasing for easy cleaning of the stainless steel knives. Adjustable pressing time for more flexibility.

Dough chamber capacity: 18 kg (round), 20 kg (square).
Movable on 4 wheels, 2 lockable.



HDD

HDS

Technical

MODEL	PIECES	WEIGHT RANGE*	TYPE OF DOUGH DIVIDER
HDD-16-E	16	250-1100 g	Round
HDD-20-E	20	200-900 g	Round
HDD-24-E	24	180-750 g	Round
HDS-10-E	10	480-2000 g	Square
HDS-20-E	20	240-1000 g	Square
HDS-10/20-E	10/20	240-2000 g	Square
HDS-20/40-E	20/40	120-1000 g	Square

El. load 1.3 kW

**subject to dough consistency*

Measurements

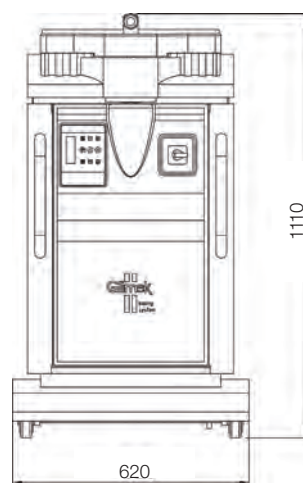



We have the equipment and expertise
you need for your bakery



Sveba-Dahlen develops, markets and manufactures bread lines, rack ovens, deck ovens, tunnel ovens, proving chambers and fermentation lines. We supply to bakeries, shops and supermarkets, industrial bakeries, restaurants and catering establishments of all sizes, all over the world.

Visit our website!



The baker's best friend

www.sveba-dahlen.com

Sveba-Dahlen AB, 518 32 Fristad, Sweden
Phone: +46 33-15 15 00, Fax: +46 33-15 15 99, mail@sveba-dahlen.se